

Additional bonus for structure development!

Example 1 :

1. You are a Senior Director (A) 🧑🏻 and you have a Director below you in the first line with an PGV of 5,000€ or more.

Your Bonus from this Director (B) 5% = 250€

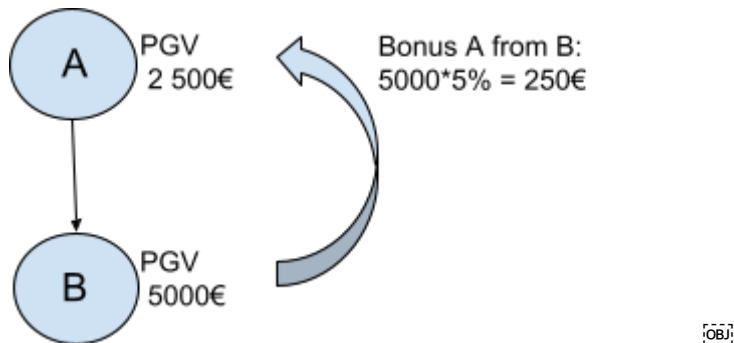

2. A new Director (C) grows under your 1st level Director (B), who becomes a 2nd level Director for you.

At the same time, the PGV of the 1st level Director (B) is reduced to 2500€.

Your Bonus of 5% from this Director (B) = 125€.

Attention !!

Here you get an additional 1% Bonus from the PGV of the 2nd level Director (C) (which is NOT included in the MARKETING plan).

You receive 1% from the PGV of the 2nd level Director (C).

5000 € * 1% = 50 €

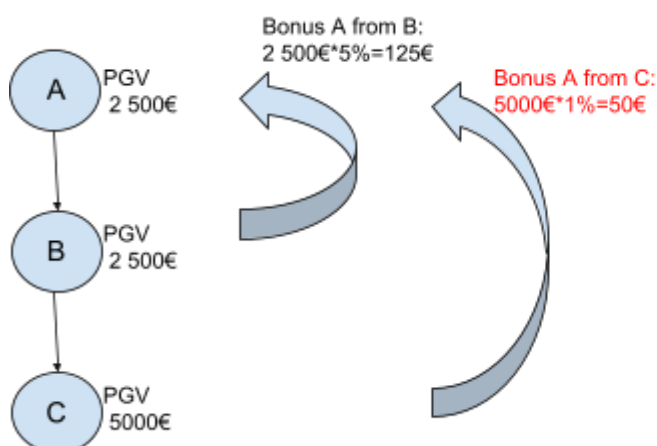

This payment will be realised each period until the PGV of the 1st level Director (B) reaches 4000 €.

From that moment the additional Bonus will not be paid, as the payment of 5% from the PGV of the 1st level Director (B) = from 200 €.

Example 2.

1. You are a Structural Director (A), you have two Directors in your first level - B and C, each from 5000€, you get a 5% Bonus from each Director (B and C) - from 250€, totalling from 500€.

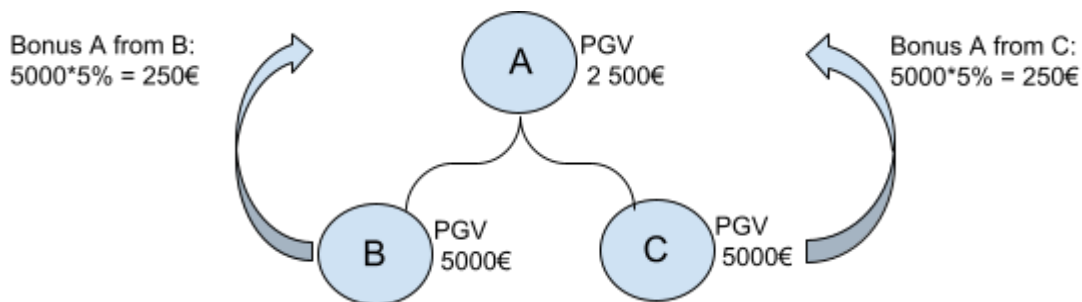

2. A 2nd level Director (D) grows under your Director (C)

Attention !!

An additional Bonus +1% of the 2nd level Director (D) is applied.

This means you receive the 1% from the 2nd level Director (D) due to the MP + additional 1% .

Total 2%.

$5000€ * 2% = 100€$

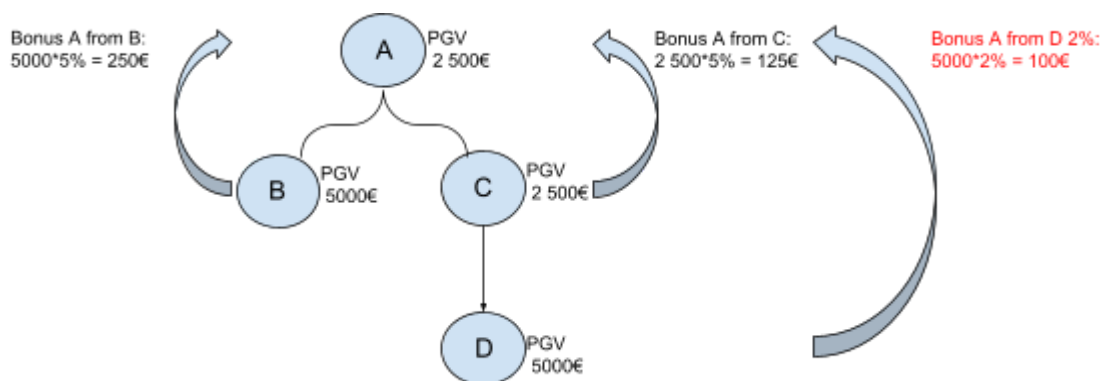

The payment will be realised each period until the PGV of the 1st level Director (C) reaches 4000€.

From that moment the additional Bonus will not be paid, and the payment from the 2nd level Director (D) will be equal to = 1%.